

Cambridgeport

SUBMITTAL

SUBMITTED TO _____
 COMPANY _____
 JOB NAME _____
 EQUIPMENT _____
 SIGNATURE _____
 DATE _____

ROOF CURB FOR YORK ROOFTOP UNITS

BQ, DJ, DH, DM, DY, XP, ZJ, ZR, 036-060
BCH, DEE, DEG, DHE, DHG 036-060
DEG, DCE, BP, DF, DM, DR, ZF 036-072
 **Note: Units with Bottom condensate Drain
 require 1RCO442. Call for Pricing**

PART #		PART #	CURB HEIGHT
CAS	YORK	INSULATED	"A"
1000004	1RCO434	1000951	14"
1004349	1RCO465	1004350	8"
1000537	N/A	1000916	18"
1000177	1RCO475	1000918	24"

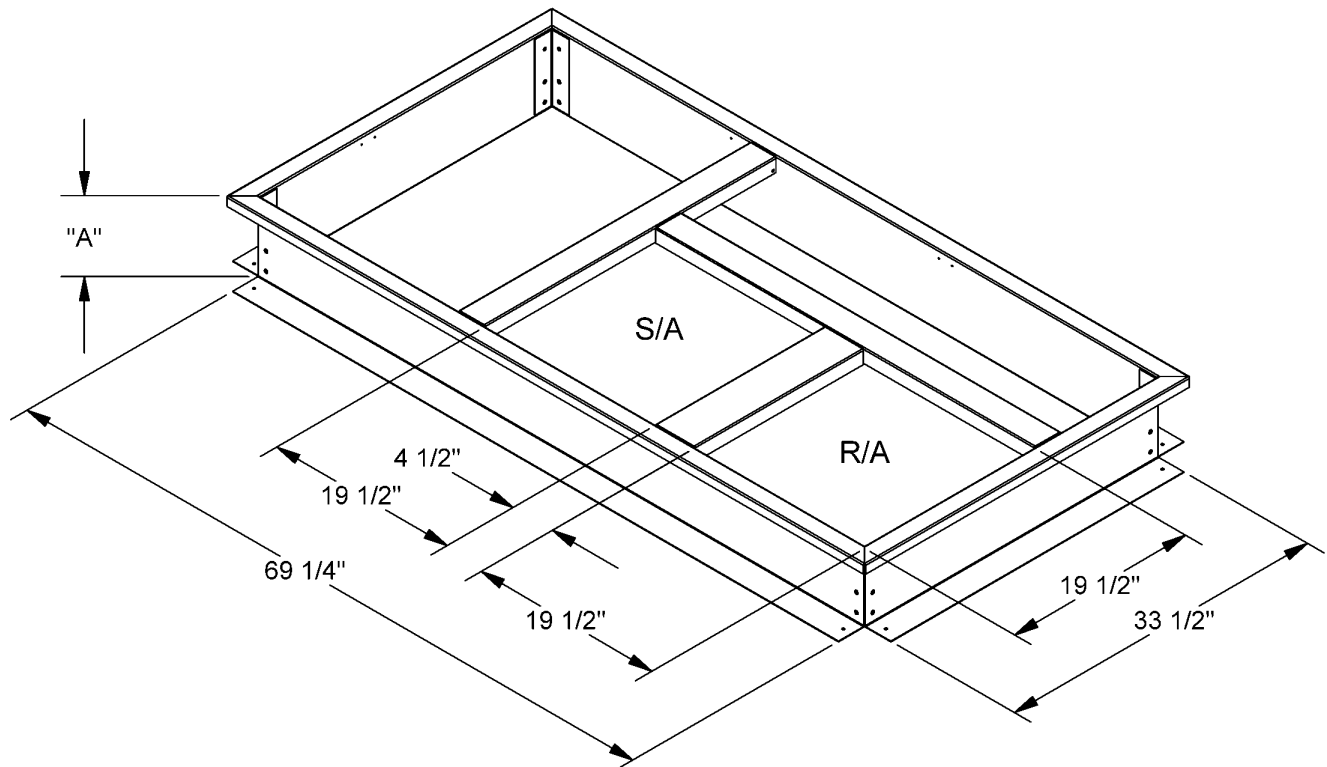

FEATURES

- MITERED TOP CORNERS
- ROOF CURB IS FABRICATED OF 18GA G90 GALVANIZED STEEL
- FULL PERIMETER WOOD NAILER
- PRE-PUNCHED ASSEMBLY HOLES AND HARDWARE INCLUDED FOR - DUCT SUPPORT INSTALLATION
- ROOF CURB IS SHIPPED UNASSEMBLED
- * CURBS ARE INTERNALLY INSULATED WITH 1" THICK 1-1/2 LB DENSITY DUCT LINER

