

Cambridgeport

SUBMITTAL

SUBMITTED TO _____
 COMPANY _____
 JOB NAME _____
 EQUIPMENT _____
 SIGNATURE _____
 DATE _____

ROOF CURBS FOR TRANE ROOFTOP UNITS

Y*C, T*C 036A, 048A, 060A
 WSC 036A, 048A

PART #		PART #	CURB HEIGHT
CAS	TRANE	INSULATED	"A"
1002582	BAYCURB042	1002745	14"
1009988	N/A	1009989	8"
1003142	N/A	1005562	18"
1003130	N/A	1005563	24"

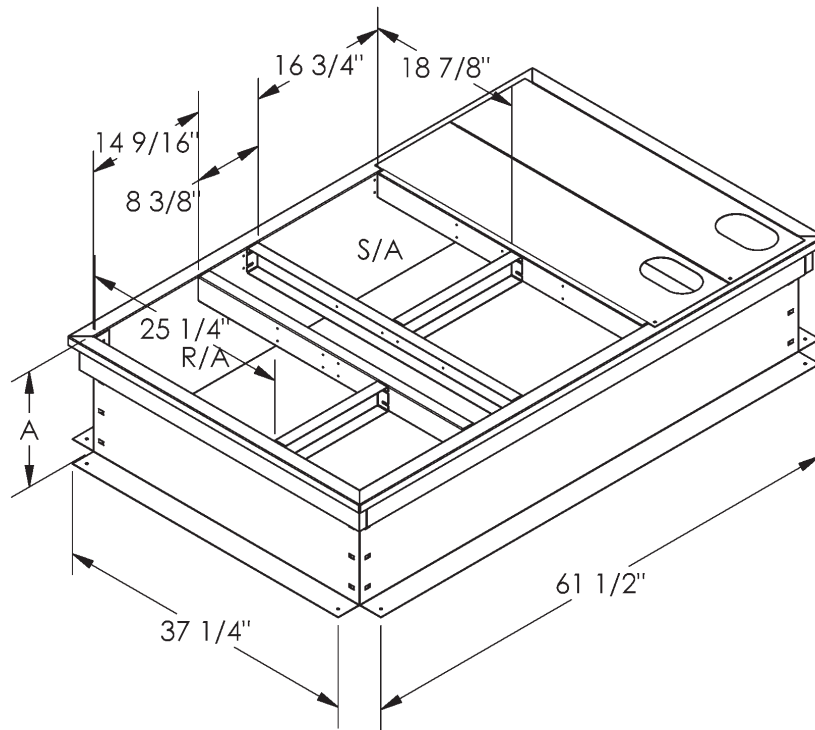

FEATURES

- MITERED TOP CORNERS
- ROOF CURB IS FABRICATED OF 18GA G90 GALVANIZED STEEL
- FULL PERIMETER WOOD NAILER
- PRE-PUNCHED ASSEMBLY HOLES AND HARDWARE INCLUDED FOR - DUCT SUPPORT INSTALLATION
- ROOF CURB IS SHIPPED UNASSEMBLED
- * CURBS ARE INTERNALLY INSULATED WITH 1" THICK 1-1/2 LB DENSITY DUCT LINER

