

DATE: _____

COMPANY: _____

JOB NAME: _____

SUBMITTED BY: _____

NOTES: _____

DROP BOX HARD DUCT SUBMITTAL DATA FOR: CARRIER UNITS 48/50PG12

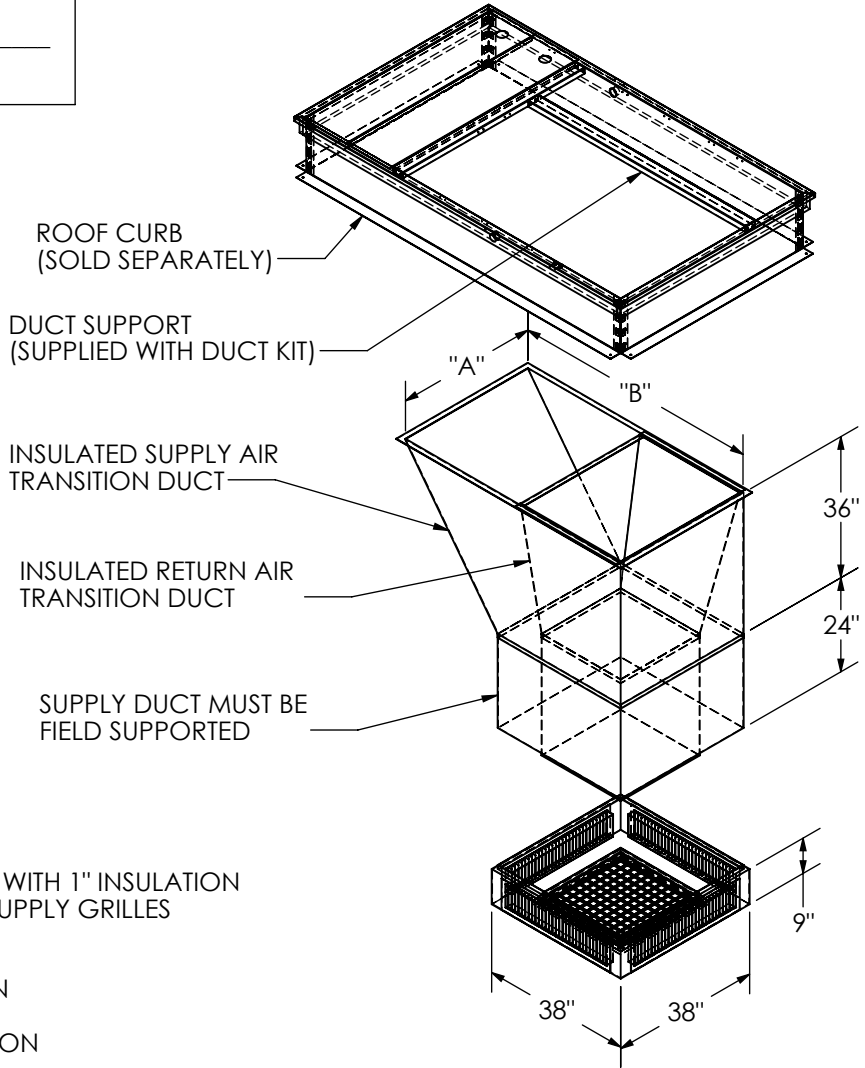

FEATURES:

DROP BOX SHIPPED ASSEMBLED, INSULATED WITH 1" INSULATION
PAINTED WHITE WITH DOUBLE DEFLECTION SUPPLY GRILLES
AND EGG CRATE RETURN

SUPPLY DUCT INSULATED WITH 1" INSULATION

RETURN DUCT INSULATED WITH 1/2" INSULATION

CAMBRIDGEPORT PART NUMBER	APPLICABLE CURB MODEL NUMBERS	"A"	"B"	SUPPLY GRILL	RETURN GRILL	NOMINAL CFM	THROW IN FT.	
							MIN	MAX
1010434	CPRFCURB0031A00SL	36 1/4"	63 5/8"	(4)-30 X 6	24" X 24"	4,000	25'	47'

NOTES:

- 1 - DO NOT INSTALL FACTORY SUPPLIED DUCT SUPPORTS UNLESS NOTED IN ASSEMBLY INSTRUCTIONS
- 2 - INSTALL CONCENTRIC DUCTWORK BEFORE SETTING A/C UNIT IN PLACE
- 3 - PLACE GASKETING ON ALL SURFACES OF DUCT FLANGE AND CURB
- 4 - ALIGN CARRIER UNIT SUPPLY OPENING TO MATCH SUPPLY OPENING OF CONCENTRIC DUCT KIT
- 5 - FIELD BAFFLES MAY BE REQUIRED FOR BALANCING
- 6 - FOR INSTALLATION SEE ASSEMBLY INSTRUCTIONS

Drawn By: CRF
Date: 2/13/08 Rev: 0

Cambridgeport AIR SYSTEMS

MEMPHIS, TN 38118

PHONE 1-877-648-2872 FAX 901-566-0035

SALISBURY, MA 01952

PHONE 1-800-648-2872 FAX 978-462-9189