

DATE: \_\_\_\_\_  
 COMPANY: \_\_\_\_\_  
 JOB NAME: \_\_\_\_\_  
 SUBMITTED BY: \_\_\_\_\_  
 NOTES: \_\_\_\_\_

# ROOF CURB SUBMITTAL #1012083

CARRIER PM48/50 038C

CURB ASSEMBLY NUMBER

1012083

REV:

Drawn By: CJT  
 Drawn Date: 04/29/08

**ESTIMATED WEIGHT: 246 LBS.**

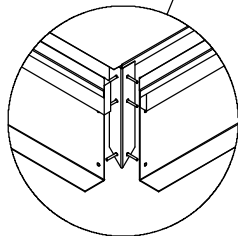
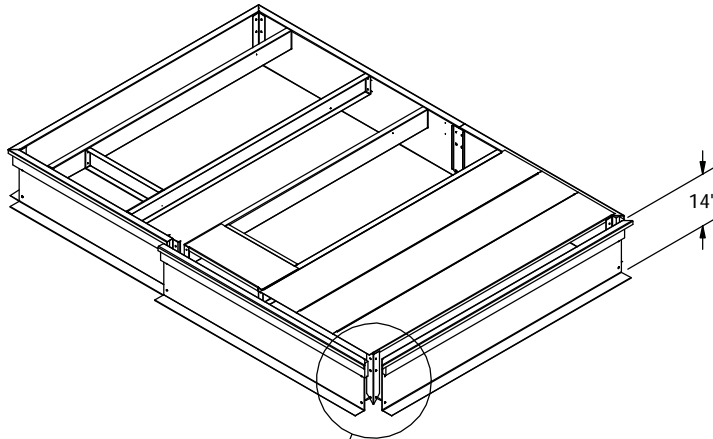

DETAIL A

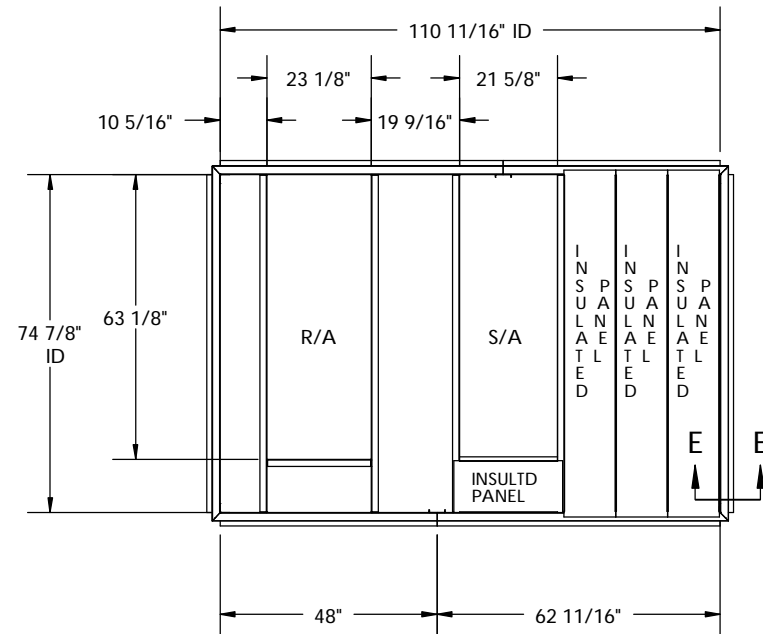
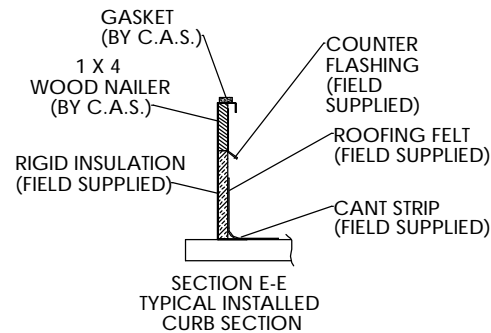

**FEATURES:**

MITERED TOP CORNERS

ROOF CURB BODY IS FABRICATED OF HEAVY GAUGE GALVANIZED STEEL.

FULL PERIMETER WOOD NAILER.

PRE-PUNCHED ASSEMBLY HOLES AND HARDWARE INCLUDED FOR DUCT SUPPORT INSTALLATION,  
 ROOF CURB IS SHIPPED KNOCKED DOWN.

ROOF CURB IS LABELED WITH RTU# IF APPLICABLE

© 2007 COX ENGINEERING COMPANY  
 DBA CAMBRIDGEPORT AIR SYSTEMS. ALL RIGHTS RESERVED. TM

**Cambridgeport**  
 AIR SYSTEMS, INC.

SALISBURY, MA 01952

PHONE 1-800-648-2872 FAX 1978-462-9189