

Cambridgeport

SUBMITTAL

SUBMITTED TO _____
 COMPANY _____
 JOB NAME _____
 EQUIPMENT _____
 SIGNATURE _____
 DATE _____

ROOF CURBS FOR ROOFTOP UNITS

Bryant:
 580J, 558J 24-28
 581J 20, 24 ; 548J24

Carrier:
 48/50 TC 24-28
 45/50 HC 20, 24

CAS PT#	CAR/BRY PART #	CAS INSULATED PART#	CURB HEIGHT (A")
1014563	CRRFCURB047A00	1014852	14"
1014850		1014853	18"
1014638	CRRFCURB048A00	1014854	24"

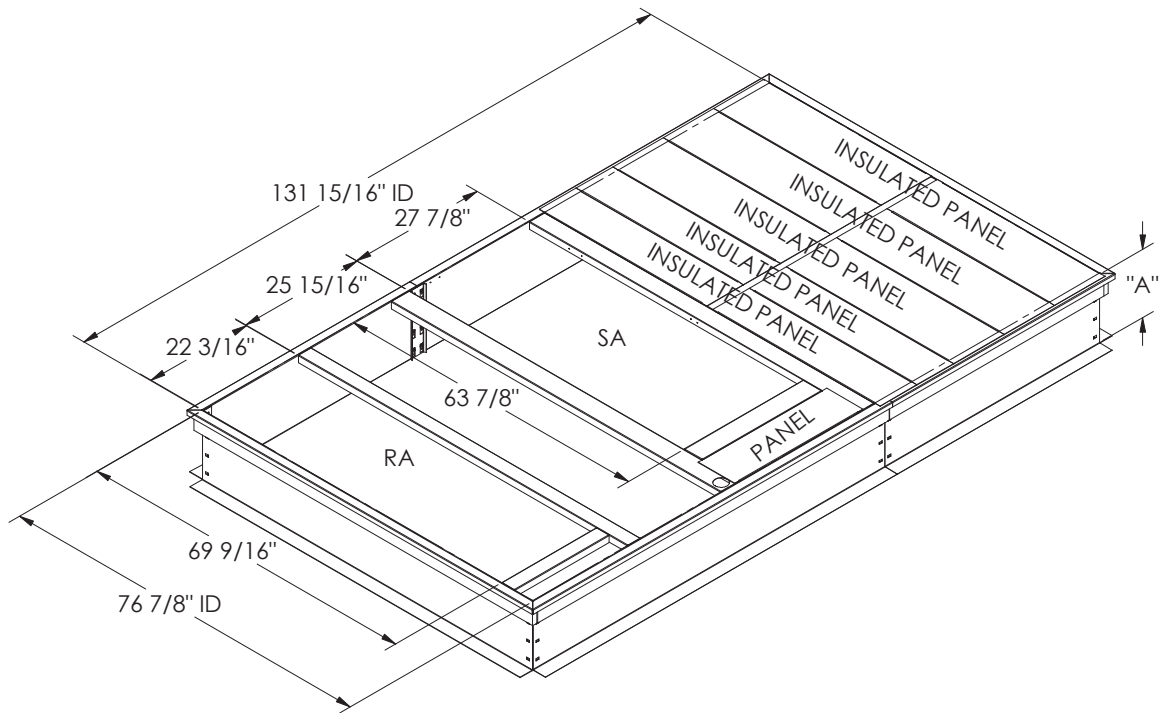

FEATURES

- MITERED TOP CORNERS
- ROOF CURB IS FABRICATED OF 18GA G90 GALVANIZED STEEL
- FULL PERIMETER WOOD NAILER
- PRE-PUNCHED ASSEMBLY HOLES AND HARDWARE INCLUDED FOR DUCT SUPPORT INSTALLATION
- ROOF CURB IS SHIPPED UNASSEMBLED
- * CURBS ARE INTERNALLY INSULATED WITH 1" THICK 1-1/2 LB DENSITY DUCT LINER

