

Cambridgeport

SUBMITTAL

ISOLATION RAILS FOR ROOFTOP UNITS

SUBMITTED TO _____
 COMPANY _____
 JOB NAME _____
 EQUIPMENT _____
 SIGNATURE _____
 DATE _____

Bryant:
 580J, 558J 24-28
 581J 20, 24 ; 548J24

Carrier:
 48/50 TC 24-28
 45/50 HC 20, 24

DESCRIPTION	PART#
1" Deflection KD	1014861
2" Deflection KD	1014862
1" Deflection ASD	1014863
2" Deflection ASD	1014864

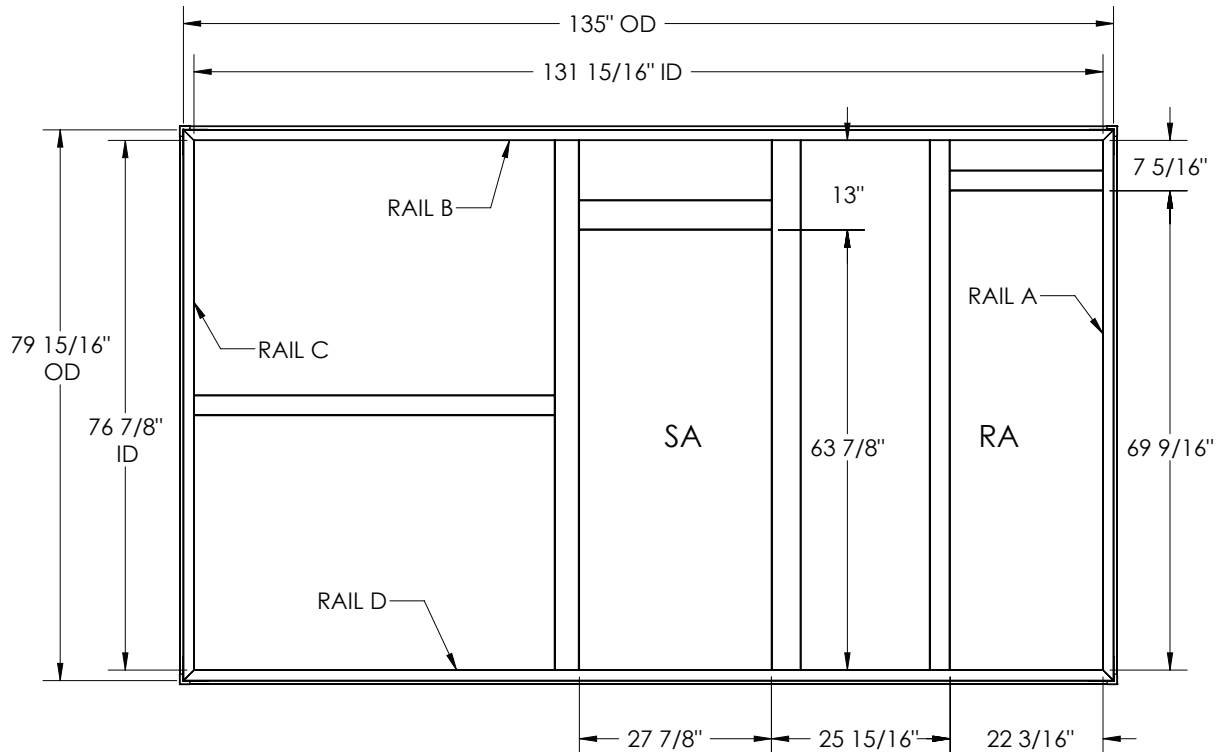

FEATURES

- SHIPPED KNOCK DOWN OR ASSEMBLED
- MITERED TOP CORNERS
- FABRICATED OF ALUMINUM EXTRUSION
- FULL PERIMETER WEATHER SEAL
- 1" OR 2" STATIC DEFLECTION
- DUCT SUPPORTS INCLUDED
- ROOF CURB SOLD SEPARATELY
- CANVAS DUCT CONNECTIONS (NOT INCLUDED)

