

# Cambridgeport

## SUBMITTAL

SUBMITTED TO \_\_\_\_\_  
 COMPANY \_\_\_\_\_  
 JOB NAME \_\_\_\_\_  
 EQUIPMENT \_\_\_\_\_  
 SIGNATURE \_\_\_\_\_  
 DATE \_\_\_\_\_

## ROOF CURBS FOR BRYANT ROOFTOP UNITS

**558J30 ; 551J28**  
**580J30 ; 581J28**

## ROOF CURBS FOR CARRIER ROOFTOP UNITS

**48/50HC 28**  
**48/50TC 30**

CAS PT#	CAR/BRY PART #	CAS INSULATED PART#	CURB HEIGHT (A")
1017086	CRRFCURB049A00	1018318	14"
1018302		1018319	18"
1017087	CRRFCURB050A00	1018320	24"

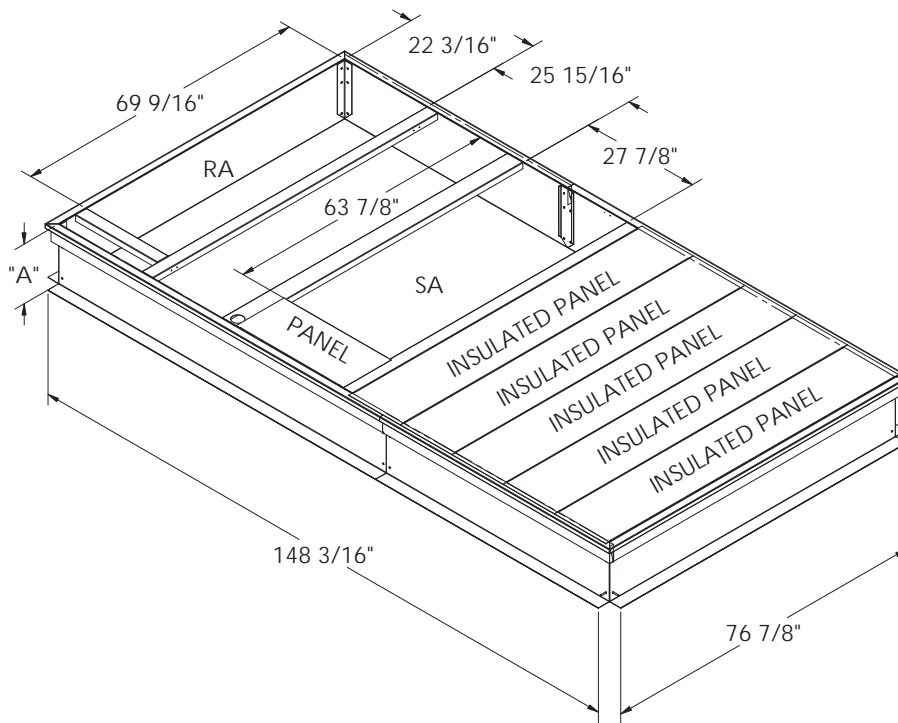

## FEATURES

- MITERED TOP CORNERS
- ROOF CURB IS FABRICATED OF 18GA G90 GALVANIZED STEEL
- FULL PERIMETER WOOD NAILER
- PRE-PUNCHED ASSEMBLY HOLES AND HARDWARE INCLUDED FOR DUCT SUPPORT INSTALLATION
- ROOF CURB IS SHIPPED UNASSEMBLED
- \* CURBS ARE INTERNALLY INSULATED WITH 1" THICK 1-1/2 LB DENSITY DUCT LINER

